

Drawings NP80-100 – P112

IC06

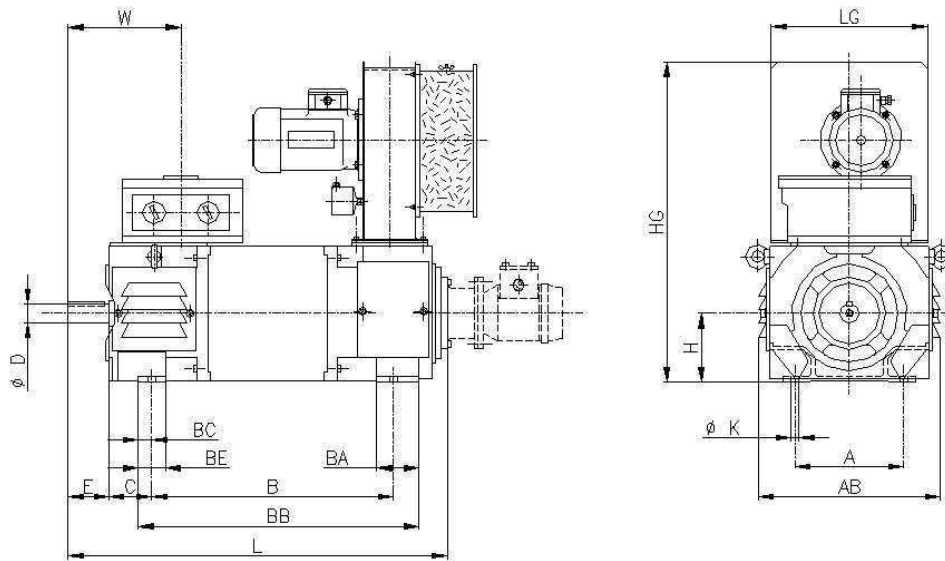

FRAME	D	E	C	B	BA	BB	BC	BE	L	W	H	HG	K	A	AB	LG
NP 80 NS2	24 j6	50	50	265	40	304	15	35	407	130	80	392	10	125	213	180
NP 80 NM2	with			290		329			432		0					
NP 80 NL2	key			325		364			467		-0.5					
NP 90 NR2	28 j6	60	56	285	40	325	19	35	460	140		400	10	140	240	210
NP 90 NS2	with			315		355			490		90					
NP 90 NM2	key			355		395			530		0					
NP 90 NL2				400		440			575		-0.5					
NP 100 NR2	38 k6	80	63	355	70	412	20	40	560	168		430	12	160	263	230
NP 100 NS2	with			395		452			600		100					
NP 100 NM2	key			445		502			650		0					
NP 100 NL2				475		532			680		-0.5					
P 112 NS2	38 k6	80	70	350	65	387	21	55	602	265	112	495	12	190	285	232
P 112 NM2	with			390		427			642		0					
P 112 NL2	key			440		477			692		-0.5					