



VA 500/ 520

Flow sensors for
compressed air
and gases incl.
temperature
measurement



Verbrauch



What are the advantages of the flow measuring technology of CS Instruments ?

1) Even under pressure, the flow sensor VA 500 is mounted by means of a standard 1/2" ball valve. During mounting and dismantling the safety ring avoids an uncontrolled ejection of the probe which may be caused by the operating pressure.

For the mounting into different pipe diameters VA 500 is available in the following probe lengths: 120, 160, 220, 300, 400 mm.

So the flow sensors are being mounted into existing pipelines with inner diameters of 1/2" upwards.

The exact positioning of the sensor in the middle of the pipe is granted by means of the engraved depth scale. The maximum mounting depth corresponds with the respective probe length. Example: VA 500 with probe length 220 mm has a maximum mounting depth of 220 mm.

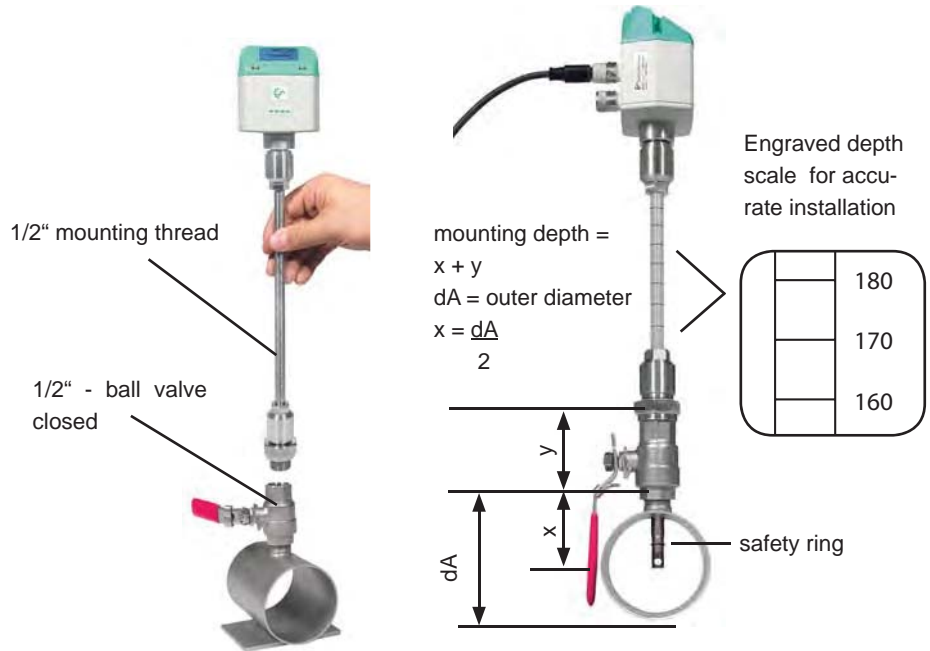

2) If there is no suitable measuring site with a 1/2" ball valve present there are two simple possibilities to set up a measuring point:

- A Weld on a 1/2" screw neck and screw on a 1/2" ball valve
- B Mount spot drilling collar incl. ball valve (see accessories)



A Screw neck



B Spot drilling collar



Drilling under pressure

By means of the drilling jig it is possible to drill under pressure through the 1/2" ball valve into the existing pipeline. The drilling chips are collected in a filter. Then the probe can be mounted as described under point A.

3) Due to the large measuring range of the probe even extreme requirements to the consumption measurement (high volume flow in small pipe diameters) can be met. The measuring range is depending on the pipe diameter - see table on the right hand side.

Flow measuring ranges VA 500 for compressed air (ISO 1217:1000 mbar, 20 °C)					
Inner diameter of pipe			VA 500 Standard (92.7 m/s)	VA 500 Max. (185.0 m/s)	VA 500 High-Speed (224.0 m/s)
Inch	mm		Measuring range from to	Measuring range from to	Measuring range from to
1/2"	16.1	DN 15	2.5...760 l/min	3.5...1516 l/min	6.0...1836 l/min
3/4"	21.7	DN 20	0.3...89 m³/h	0.4...178 m³/h	0.7...215 m³/h
1"	27.3	DN 25	0.5...148 m³/h	0.6...295 m³/h	1.1...357 m³/h
1 1/4"	36.0	DN 32	0.9...280 m³/h	1.2...531 m³/h	2.5...644 m³/h
1 1/2"	41.9	DN 40	1.2...366 m³/h	1.5...732 m³/h	3.0...886 m³/h
2"	53.1	DN 50	2...600 m³/h	2.5...1198 m³/h	4.6...1450 m³/h
2 1/2"	71.1	DN 65	3.5...1096 m³/h	5...2187 m³/h	7...2648 m³/h
3"	84.9	DN 80	5...1570 m³/h	7...3133 m³/h	12...3794 m³/h
4"	110.0	DN 100	9...2645 m³/h	12...5279 m³/h	16...6391 m³/h
5"	133.7	DN 125	13...3912 m³/h	18...7808 m³/h	24...9453 m³/h
6"	159.3	DN 150	18...5560 m³/h	25...11097 m³/h	43...13436 m³/h
8"	200.0	DN 200	26...8786 m³/h	33...17533 m³/h	50...21230 m³/h
10"	250.0	DN 250	40...13744 m³/h	52...27429 m³/h	80...33211 m³/h
12"	300.0	DN 300	60...19815 m³/h	80...39544 m³/h	100...47881 m³/h



VA 500 - Flow sensor for compressed air and gases

The new VA 500 for flow measurement of compressed air and gases, optionally with display for flow in m³/h and total flow in m³. Contrary to the previously used bridge circuit the newly developed evaluation electronics records all measured values digitally. This leads to a better accuracy also in case of large measuring spans of 1:1000.

Special features:

- RS 485 interface, Modbus-RTU as a standard
- Incl. temperature measurement
- Integrated display for m³/h and m³
- Usable from 1/2" to 12" (DN 300)
- Easy installation under pressure
- 4...20 mA analogue output for m³/h resp. m³/min
- Pulse output for m³
- Inner diameter adjustable via keypad
- Consumption counter resettable
- Adjustable via keys at the display: Gas type, reference conditions, °C and mbar, 4...20 mA scaling, pulse weight

flexible mounting
thread G 1/2"

safety ring
Ø 11.7 mm



Inner diameter adjustable
via keypad

Technical data VA 500

Parameters: m³/h, l/min (1000 mbar, 20°C) in case of compressed air resp. Nm³/h, NI/min (1013 mbar, 0°C) in case of gases

Units adjustable via keys at display: m³/h, m³/min, l/min, l/s, ft/min, cfm, m/s, kg/h, kg/min

Adjustable via keypad: diameter for volume flow calculation, counter resettable

Meas. principle: calorimetric measurement

Sensor: Thermal mass flow sensor

Meas. medium: air, gases

Gas types adjustable via external devices DS 400, DS 500, PI 500 air, nitrogen, argon, nitrous oxide, CO₂, oxygen

Meas. range: see table measuring ranges page 80

Accuracy: ± 1.5 % of m.v. ± 0.3 % of f.s. on request
± 1.0 % of m.v. ± 0.3 % of f.s. (f.s.: of full scale)

Operating temp.: -30...110 °C probe tube
-30...80 °C housing

Operating pressure: up to 50 bar

Digital output: RS 485 interface, Modbus RTU

Analogue output: 4...20 mA for m³/h resp. l/min; on request: scaling for cfm, m³/min, l/min, l/s, ft/min, m/s

Pulse output: 1 pulse per m³ resp. per liter galvanically separated

Power supply: 18...36 VDC, 5 W

Burden: < 500 Ω

Housing: polycarbonate (IP 65)

Probe tube: stainless steel, 1.4301 mounting length 220 mm, Ø 10 mm

Mounting thread: G 1/2"

Description	Order No.
VA 500 flow sensor in basic version: Standard (92.7 m/s), probe length 220 mm, without display	0695 5001
Options for VA 500:	
Display	Z695 5000
Max. version (185 m/s)	Z695 5003
HighSpeed version (224 m/s)	Z695 5002
1 % Accuracy of m.v. ± 0,3 % of f.s.	Z695 5005
Probe length 120 mm	ZSL 0120
Probe length 160 mm	ZSL 0160
Probe length 300 mm	ZSL 0300
Probe length 400 mm	ZSL 0400
Connection cables:	
Connection cable, 5 m (power supply, analogue output, pulse output)	0553 0104
Connection cable, 10 m (power supply, analogue output, pulse output)	0553 0105
Pulse cable for flow sensors with M12 plug, length 5 m	0553 0106
Pulse cable for flow sensors with M12 plug, length 10 m	0553 0107
Further accessories:	
CS Service Software for FA/VA 500 sensors incl. PC connection set, USB interface and interface adapter to the sensor	0554 2007
Mains unit in wall housing 100-240 V, 10 VA, 50-60 Hz/24 VDC, 0.35 A	0554 0108
AC adapter plug 100-240 V AC/ 24 V for VA/FA 500/520	0554 0109
External wall display chart recorder DS 400	0500 4000
5 point precision calibration with ISO certificate	3200 0001



VA 520

The affordable flow meter for compressed air and gases incl. temperature measurement

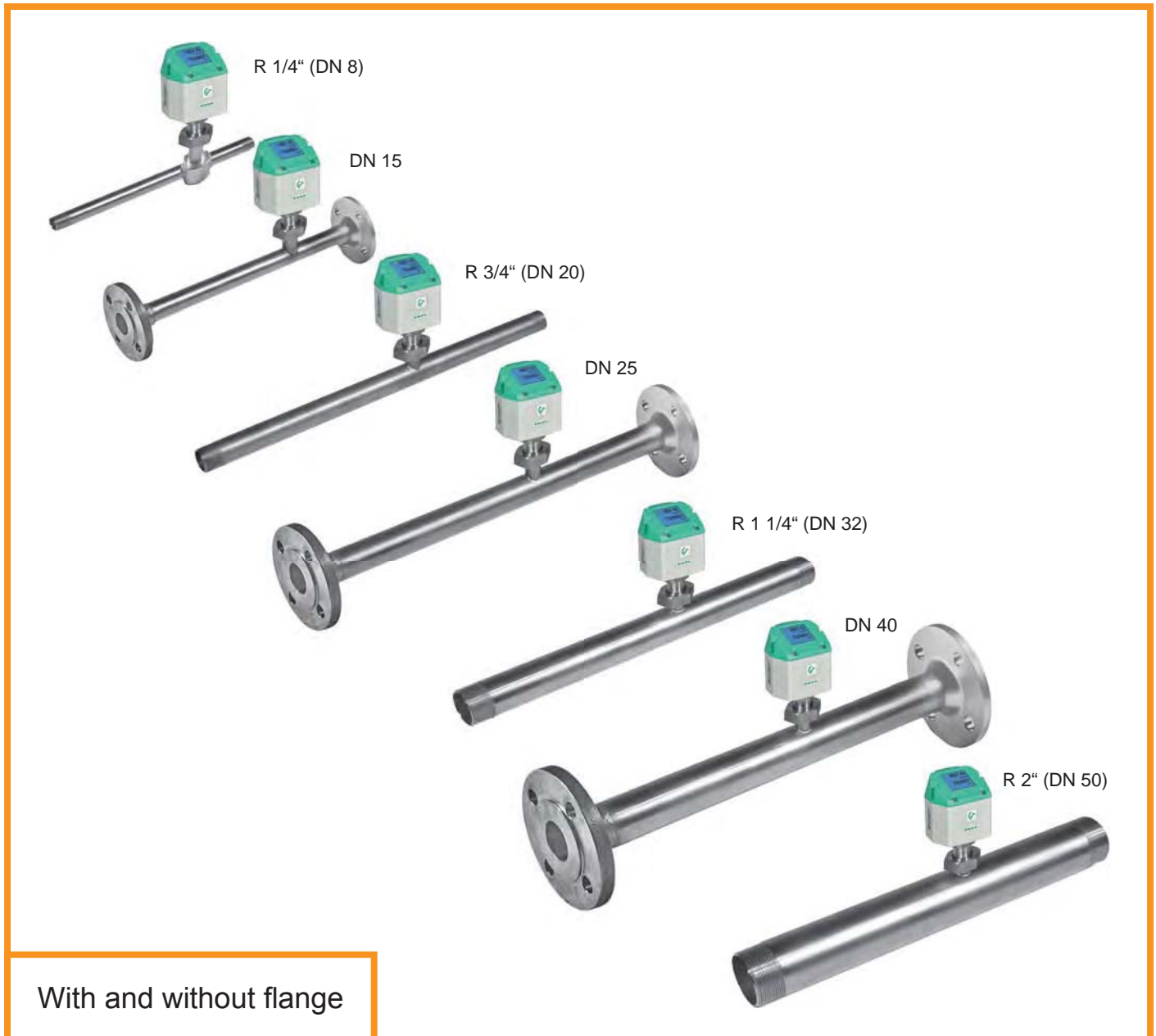

Intelligent solutions for accurate flow measurement for compressed air and gases

The new affordable flow sensors VA 520 work according to the approved calorimetric measuring principle. An additional pressure and temperature compensation is not necessary. Contrary to the previously used

bridge circuit the newly developed evaluation electronics records all measured values digitally. This enables very precise and fast measurements. Due to the new evaluation electronics all VA 520 have an integrated Modbus output as a standard. So all parameters can be transferred via Modbus. Due to its compact design it is possible to monitor all compressed air systems from the compressor to the smallest compressed air tool (1/4" to 2 inch) with the new affordable flow sensor VA 520.

VA 500 flow sensors are available for larger pipe diameters from DN 50 to DN 300. Apart from compressed air also other gases like e.g. nitrogen, oxygen and CO₂ can be measured.



Removal of the measuring device without complete dismounting of the measuring section



In case of compressed air meters with integrated measuring section the „measuring device“ cannot be removed. For this reason an expensive bypass line is necessary. The design of **VA 520** enables the removal and cleaning of the „measuring device“ with e.g. soap water without any dismounting of the measuring section. A closing cap grants a continuous use of the line for the duration of the cleaning. A bypass line is not necessary. The alignment pin grants an accurate installation of the measuring device.

In most cases the compressed air is not free from oil, condensate, dirt and particles. In the course of time this leads to a soiling of the flow meters which may cause errors in mea-

surement or even a total breakdown. The flow sensors which have been on the market up to now generally cannot be cleaned and will be exchanged if they are soiled. In

2 Stationary use



For stationary use there are the following outputs available for the data transfer to a building management system or PLC:

4...20 mA for actual flow.

Pulse output (galvanically separated) for the total consumption.

3 Mobile use



By means of quick couplings the flow sensor can be integrated quickly into the feed hose of a machine. During the shutdown of the machine it is possible to determine the leak rate, the actual flow can be obtained when the machine is running. The power supply is effected via the power socket by means of the mains unit. For data recording over a longer period of time we recommend to use the compressed air analyzer DS 400 mobile.

4 Solution for large pipe diameters



The approved flow sensor **VA 500** is available for pipe diameters of 2" to DN 300. Its constructively sophisticated design enables the installation into pipes with nominal diameters up to DN 300 even under pressure. The installation is effected by means of standard 1/2" ball valve.



VA 520 - The advantages at a glance

NEW: Modbus-RTU output

4...20 mA output for actual flow

Pulse output for total flow (counter reading)

Measuring device removable: Dismounting of the whole measuring section is not necessary, no bypass required

Screw-in thread:

Easy installation into the existing pipeline due to integrated measuring section (suitable for 1/4", 1/2", 3/4", 1", 1 1/4", 1 1/2" or 2" lines)

High measuring accuracy due to defined measuring section (inlet and outlet section)

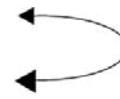
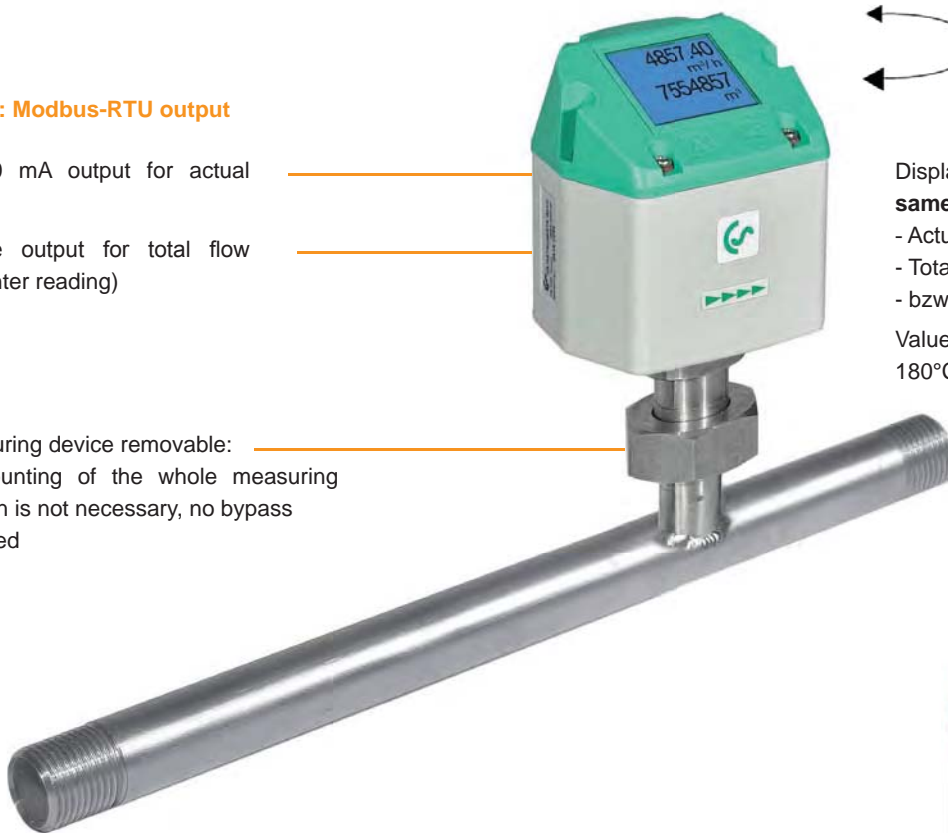

Display twistable by 180° e.g. in case of reverse flow direction

Display shows 2 values at the same time:

- Actual flow in m³/h, l/min,...
- Total consumption (counter reading) in m³, l
- bzw. temperature measurement

Values indicated in the display turnable by 180°, e.g. in case of overhead installation



At the touch of a button:

- Reset of counter reading
- selection of units
- zero-point adjustment, leak flow volume suppression

Application-technological features of the flow sensors VA 520:

- The integrated Modbus interface enables the connection to superordinated control systems like energy management systems, building management systems, SPS, SCADA,
- Easy and affordable installation
- Units freely selectable via keys at the display m³/h, m³/min, l/min, l/s, kg/h, kg/min, kg/s, cfm
- Compressed air counter up to 1.999.999.999 m³. Resetable to „zero“ via keypad
- Analogue output 4...20 mA, pulse output (galvanically separated)
- High measuring accuracy also in the lower measuring range (ideal for leakage measurement)
- Negligibly small loss of pressure
- Calorimetric measuring principle, no additional pressure and temperature measurement necessary, no mechanically moved parts
- Comprehensive diagnosis functions can be read out at the display or by remote access via Modbus-RTU like e. g. exceeding Max./Min values °C, calibration cycle, error codes, serial number. All parameters can be read out and changed via Modbus

Application range of VA 520:

- Compressed air balancing, compressed air consumption measurement
- Leakage air/leak rate determination
- Mobile compressed air measurement in front of single machines / plants
- Flow measurement of process gases like e.g. nitrogen, CO2, oxygen, argon, nitrous oxide
- Flow measurement at nitrogen generators

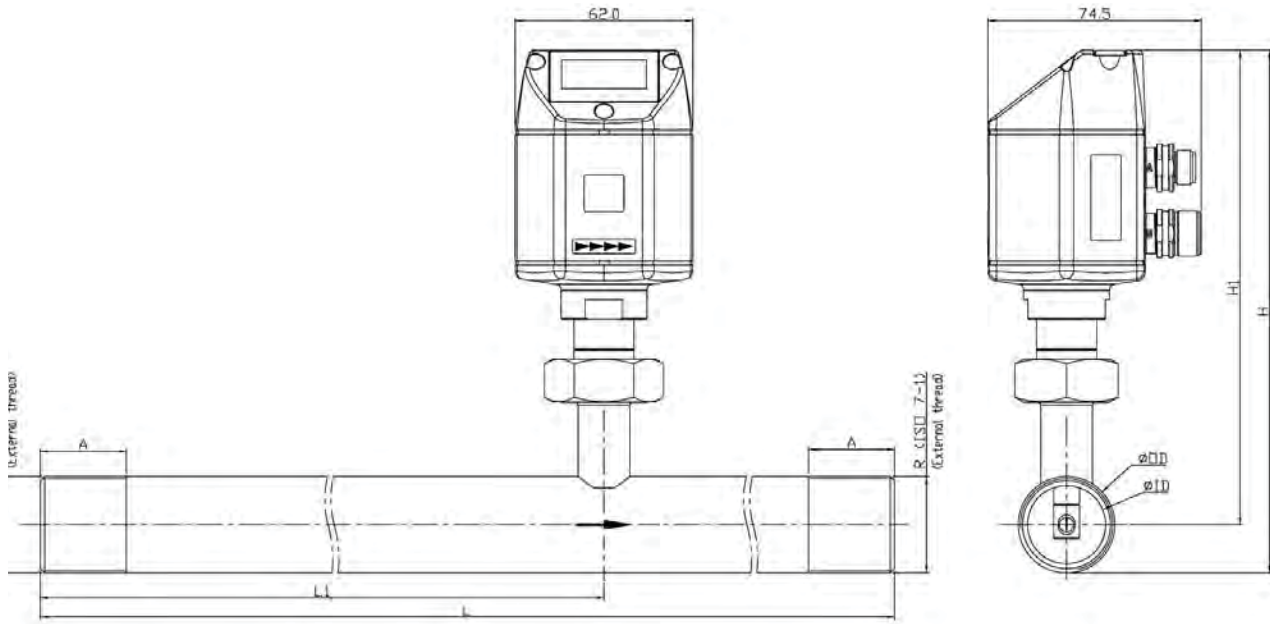

Flow measuring ranges VA 520 for compressed air (ISO 1217:1000 mbar, 20 °C)

Connection thread	Outer pipe dia. mm	Inner pipe dia. mm	Measuring range from to	L mm	L1 mm	H mm	H1 mm	A mm
R 1/4"	13.7	8.9	0.1 90 l/min	194	137	174.7	165.7	15
R 1/2"	21.3	16.1	0.2 90 m³/h	300	210	176.4	165.7	20
R 3/4"	26.9	21.7	0.3 170 m³/h	475	275	179.2	165.7	20
R 1"	33.7	27.3	0.5 290 m³/h	475	275	182.6	165.7	25
R 1 1/4"	42.4	36.0	0.7 530 m³/h	475	275	186.9	165.7	25
R 1 1/2"	48.3	41.9	1.0 730 m³/h	475*	275	186.9	165.7	25
R 2"	60.3	53.1	2.0 1195 m³/h	475*	275	195.9	165.7	30

*Attention: Shortened inlet section! Please observe the recommended minimum inlet section (length = 10 x inner diameter) on site!

**Technical data
VA 520**

Parameters: m³/h, l/min (1000 mbar, 20°C) in case of compressed air resp. Nm³/h, NI/min (1013 mbar, 0°C) in case of gases

Units adjustable via keys at display: m³/h, m³/min, l/min, l/s, ft/min, cfm, m/s, kg/h, kg/min

Meas. principle: calorimetric measurement

Sensor: Thermal mass flow sensor

Meas. medium: air, gases

Gas types adjustable via external device DS 400, DS 500, PI 500 air, nitrogen, argon, nitrous oxide, CO₂, oxygen

Meas. range: see table at the left

Accuracy: ± 1.5 % of m.v. ± 0.3 % of f.s. (m.v.: of meas. value) ± 1.0 % of m.v. ± 0.3 % of f.s. (f.s.: of full scale)

Operating temp.: -30...80 °C

Operating pressure: up to 16 bar optional up to PN 40

Digital output: RS 485 interface, Modbus-RTU

Analogue output: 4...20 mA for m³/h resp. l/min

Pulse output: 1 pulse per m³ resp. per liter galvanically separated

Power supply: 18...36 VDC, 5 W

Burden: < 500 Ω

Housing: polycarbonate

Meas. section: stainless steel, 1.4301 or 1.4404

Mounting thread meas. section: R 1/4", R 1/2", R 3/4", R 1", R 1 1/4", R 1 1/2", R 2" external thread.

Description	Order No. Stainless steel 1.4404	Order No. Stainless steel 1.4301
VA 520 flow sensor with integrated 1/4" measuring section	0695 1520	0695 0520
VA 520 flow sensor with integrated 1/2" measuring section	0695 1521	0695 0521
VA 520 flow sensor with integrated 3/4" measuring section	0695 1522	0695 0522
VA 520 flow sensor with integrated 1" measuring section	0695 1523	0695 0523
VA 520 flow sensor with integrated 1 1/4" measuring section	0695 1526	0695 0526
VA 520 flow sensor with integrated 1 1/2" measuring section	0695 1524	0695 0524
VA 520 flow sensor with integrated 2" measuring section	0695 1525	0695 0525
Option High-pressure version PN 40		Z695 0411
Option 1 % Accuracy of m.v. ± 0,3 % of f.s.		Z695 5005
Special measuring range VA 520 according to customer's requirements		Z695 4006
Connection cables:		
Connection cable 5 m (power supply, analogue output)		0553 0104
Connection cable 10 m (power supply, analogue output)		0553 0105
Pulse cable for flow sensors with M12 plug, length 5 m		0553 0106
Pulse cable for flow sensors with M12 plug, length 10 m		0553 0107
Further accessories:		
Closing cap for meas. section (Material: Aluminium)		0190 0001
Closing cap for meas. section (Material: Stainless steel 1.4404)		0190 0002
CS Service Software for FA/VA sensors incl. PC connection set, USB interface and interface adapter to the sensor		0554 2007
Mains unit in wall housing 100-240 V, 10 VA, 50-60 Hz/24 VDC, 0.35 A		0554 0108
AC adapter plug 100-240 V AC/ 24 V for VA/FA 500/520		0554 0109
5 point precision calibration with ISO certificate		3200 0001



VA 520 - The advantages at a glance

NEW: Modbus-RTU output

- 4...20 mA output for actual flow
- Pulse output for total flow (counter reading)

Measuring device removable:
Dismounting of the whole measuring section is not necessary, no bypass required

Display shows 2 values at the same time:

- Actual flow in m³/h, l/min,...
- Total consumption (counter reading) in m³, l
- bzw. temperature measurement

Values indicated in the display turnable by 180°C, e.g. in case of overhead installation

Easy installation into the existing pipeline due to integrated measuring section and weld neck flange (according to EN 1092-1 PN 40)

High measuring accuracy due to defined measuring section (inlet and outlet section)

At the touch of a button:

- reset of counter reading
- selection of units
- zero-point adjustment, leak flow volume suppression

Display twistable by 180°C e.g. in case of reverse flow direction

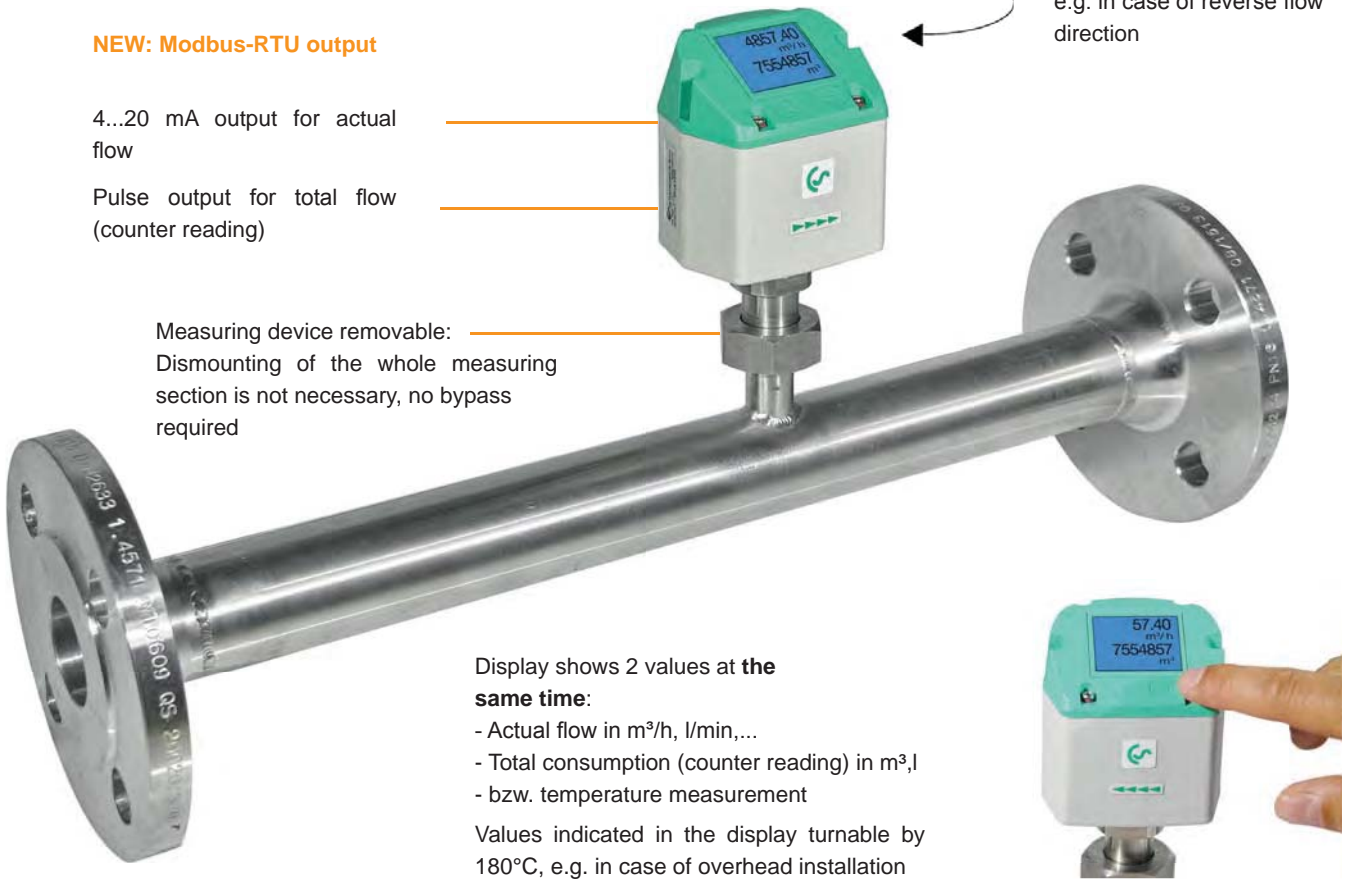

Application-technological features of the flow sensors VA 520:

- The integrated Modbus interface enables the connection to superordinated control systems like energy management systems, building management systems, SPS, SCADA,
- Easy and affordable installation
- Units freely selectable via keys at the display m³/h, m³/min, l/min, l/s, kg/h, kg/min, kg/s, cfm
- Compressed air counter up to 1.999.999.999 m³. Resetable to „zero“ via keypad
- Analogue output 4...20 mA, pulse output (galvanically separated)
- High measuring accuracy also in the lower measuring range (ideal for leakage measurement)
- Negligibly small loss of pressure
- Calorimetric measuring principle, no additional pressure and temperature measurement necessary, no mechanically moved parts
- Comprehensive diagnosis functions can be read out at the display or by remote access via Modbus-RTU like e. g. exceeding Max./Min. values °C, calibration cycle, error codes, serial number. All parameters can be read out and changed via Modbus

Application range of VA 520:

- Compressed air balancing, compressed air consumption measurement
- Leakage air/leak rate determination
- Flow measurement of process gases like e.g. nitrogen, CO₂, oxygen, argon, nitrous oxide
- Flow measurement at nitrogen generators

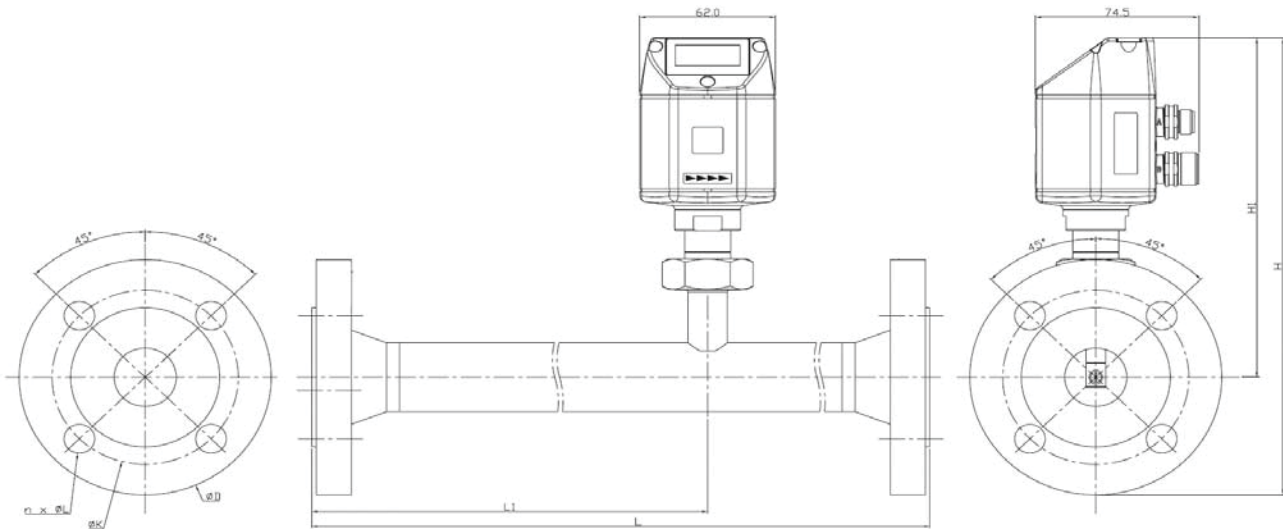

Flow measuring ranges VA 520 for compressed air (ISO 1217:1000 mbar, 20 °C)					Flange DIN EN 1092-1						
Measuring section	Outer pipe dia. mm	Inner pipe dia. mm	Measuring range from to		L mm	L1 mm	H mm	H1 mm	ØD	ØK	n x ØL
DN 15	21.3	16.1	0.2	90 m³/h	300	210	213.2	165.7	95	65	4 x 14
DN 20	26.9	21.7	0.3	170 m³/h	475	275	218.2	165.7	105	75	4 x 14
DN 25	33.7	27.3	0.5	290 m³/h	475	275	223.2	165.7	115	85	4 x 14
DN 32	42.4	36.0	0.7	530 m³/h	475	275	235.7	165.7	140	100	4 x 18
DN 40	48.3	41.9	1.0	730 m³/h	475*	275	240.7	165.7	150	110	4 x 18
DN 50	60.3	53.1	2.0	1195 m³/h	475*	275	248.2	165.7	165	125	4 x 18

*Attention: Shortened inlet section! Please observe the recommended minimum inlet section (length = 10 x inner diameter) on site

Technical data VA 520

Parameters: m³/h, l/min (1000 mbar, 20°C) in case of compressed air resp. Nm³/h, NI/min (1013 mbar, 0°C) in case of gases

Units adjustable via keys at display: m³/h, m³/min, l/min, l/s, ft/min, cfm, m/s, kg/h, kg/min

Meas. principle: calorimetric measurement

Sensor: Thermal mass flow sensor

Meas. medium: air, gases

Gas types adjustable via external device DS 400, DS 500, PI 500 air, nitrogen, argon, nitrous oxide, CO2, oxygen

Meas. range: see table at the left

Accuracy: ± 1.5 % of m.v. ± 0.3 % of f.s. (m.v.: of meas. value) ± 1.0 % of m.v. ± 0.3 % of f.s. (f.s.: of full scale)

Operating temp.: -30...80 °C

Operating press.: up to 16 bar
Optional up to PN 40

Digital output: RS 485 interface, Modbus-RTU

Analogue output: 4...20 mA for m³/h resp. l/min

Pulse output: 1 pulse per m³ resp. per liter galvanically separated

Power supply: 18...36 VDC, 5 W

Burden: < 500 Ω

Housing: polycarbonate (IP 65)

Meas. section: stainless steel 1.4301 or 1.4404

Flanges: Weld neck flange according to DIN EN 1092-1, Groove-faced and tongue-faced on request

Description	Order No.
VA 520 flow sensor with integrated DN 15 measuring section with weld neck flange	0695 2521
VA 520 flow sensor with integrated DN 20 measuring section with weld neck flange	0695 2522
VA 520 flow sensor with integrated DN 25 measuring section with weld neck flange	0695 2523
VA 520 flow sensor with integrated DN 32 measuring section with weld neck flange	0695 2526
VA 520 flow sensor with integrated DN 40 measuring section with weld neck flange	0695 2524
VA 520 flow sensor with integrated DN 50 measuring section with weld neck flange	0695 2525
Option High-pressure version PN 40	Z695 0411
Option 1 % Accuracy of m.v. ± 0,3 % of f.s.	Z695 5005
Special measuring range VA 520 according to customer's requirements	Z695 4006
Connection cables:	
Connection cable 5 m (power supply, analogue output)	0553 0104
Connection cable 10 m (power supply, analogue output)	0553 0105
Pulse cable for flow sensors with M12 plug, length 5 m	0553 0106
Pulse cable for flow sensors with M12 plug, length 10 m	0553 0107
Further accessories:	
Closing cap for meas. section (Material: Aluminium)	0190 0001
Closing cap for meas. section (Material: Stainless steel 1.4404)	0190 0002
CS Service Software for FA/VA sensors incl. PC connection set, USB interface and interface adapter to the sensor	0554 2007
Mains unit in wall housing 100-240 V, 10 VA, 50-60 Hz/24 VDC, 0.35 A	0554 0108
AC adapter plug 100-240 V AC/ 24 V for VA/FA 500/520	0554 0109
5 point precision calibration with ISO certificate	3200 0001