

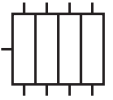

**Progressive distributor
VPB**



Use:

In progressive mode based central lubrication systems.

The main features of **WOERNER** progressive distributors are as follows:

- **Accurate proportioning volumes.**
- **3 different proportioning volumes** selectable in accordance with the lubricant volume required.
- **Extremely long service life** due to refined sliding surfaces.
- **Easy combination** of opposing outlets
- **Various options for monitoring**

Technical data:

Proportioning volume per cycle:
 Distinctive colour green 0,09 cm³
 Distinctive colour yellow 0,14 cm³
 Distinctive colour red 0,20 cm³

Lubrication point connections at max.: 20

Operating pressure at max.: 150 bar

Throughput volume in case of:
 Oil at max.: 700 cm³/min
 Grease at max.: 70 cm³/min

Delivery medium:
 Oil-viscosity: >6 cP
 Grease up to: NLGI category 2

Material:
 Outer body:
 VPB-B: Aluminium anodised
 VPB-H: Bronze
 seawater-resistant

Internal parts: Steel

Temperature range: -20 ... +80 °C

Lubricant: The intended lubricant must be suitable for use with centralized lubrication equipment.

Mounting position: usually as needed

Note: In case of heavy vibration or shock load, install the distributor such that piston axes are situated vertically to the main direction of shock impact.

The distributor must not be "distorted". Therefore, when mounting it, be careful that the supporting surface is flat.

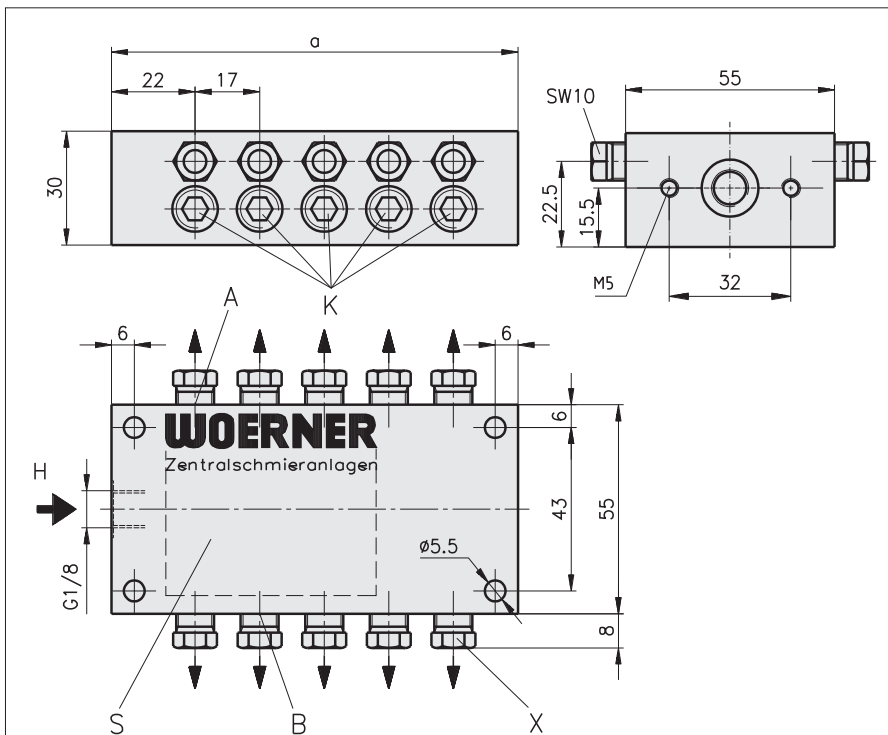

- A = Mounting point at distributor (for viewing indicator and electrical functionality check)
- B = Mounting point for viewing indicator at distributor (if point A is occupied)
- H = Input line
- K = Proportioning volume distinctive colours (see technical data)
- S = Note to proportioning volume distinctive colours
- X = Outlet screwing for pipe outer diameters 4 or 6, connection hole in distributor for double-cone ring 6 DIN 3862 and ALL6 male fitting DIN 3871

Number of outlets	Length "a"	Weight [kg]	
		VPB-B	VPB-H
6	73	0,38	0,84
8	90	0,47	1,04
10	107	0,57	1,27
12	124	0,66	1,47
14	141	0,76	1,69
16	158	0,85	1,89
18	175	0,95	2,11
20	192	1,04	2,31

- Subject to modifications -



Visual check "S"

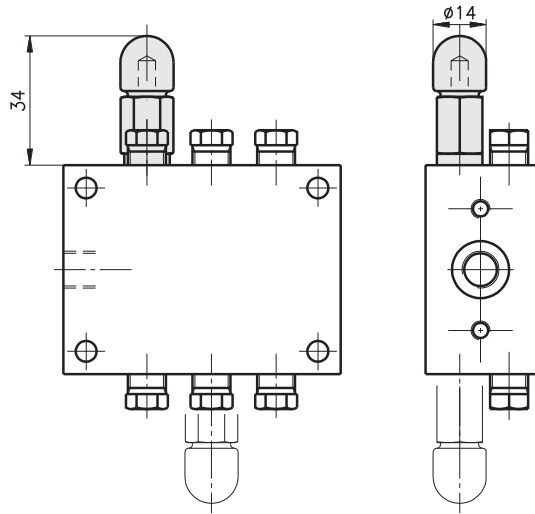

Functional checks:

Visual check "S":

In a translucent polyamide receptacle, a red pin being fixed to the piston shows the piston's movement.

Receptacle material: Polyamide, translucent
 Ambient temperature: -10 ... +80 °C
 Weight: 0,035 kg
 Mounting point at distributor: A or B

Version "M1"

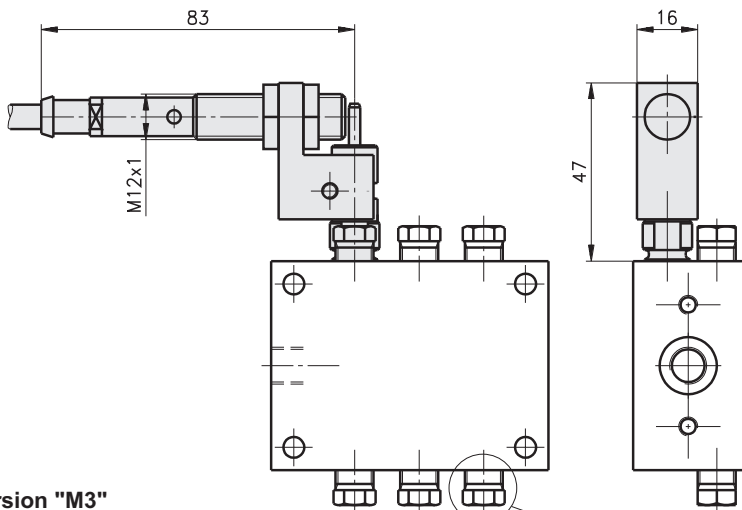

Version "M3"

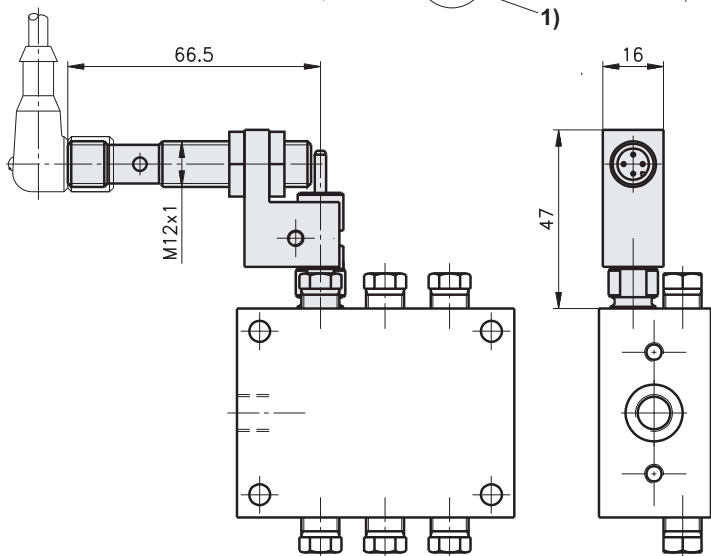

Electrical check with initiator:

A pin being connected with the piston attenuates an initiator once per cycle.

Material:
 Holder: Aluminium
 VPB-B: Bronze
 VPB-H: Bronze
 Indicator pin: 1.4521

¹⁾ On the functional checking device "M", the metering volume at the last point (opposite the initiator's side) decreases by 25 % for design-related reasons.

Version initiator "M1" with cable:

Operating voltage: 8 ... 30 VDC
 Residual ripple: ≤10 %
 Output: Closer, plus switching PNP
 Load current at max.: 400 mA
 Protection system: IP67
 Connection: Cable 2 m

Connection diagram:

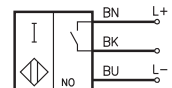

Version initiator "M3" with 4-pin unit plug (M12):

(for matching cable jack see auxiliaries)

Operating voltage: 8 ... 30 VDC
 Residual ripple: ≤10 %
 Output: Closer, plus switching PNP
 Load current at max.: 400 mA
 Protection system: IP65
 Connection: Unit plug

Connection diagram:

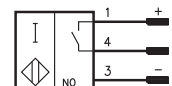

- Subject to modifications -



- Subject to modifications -

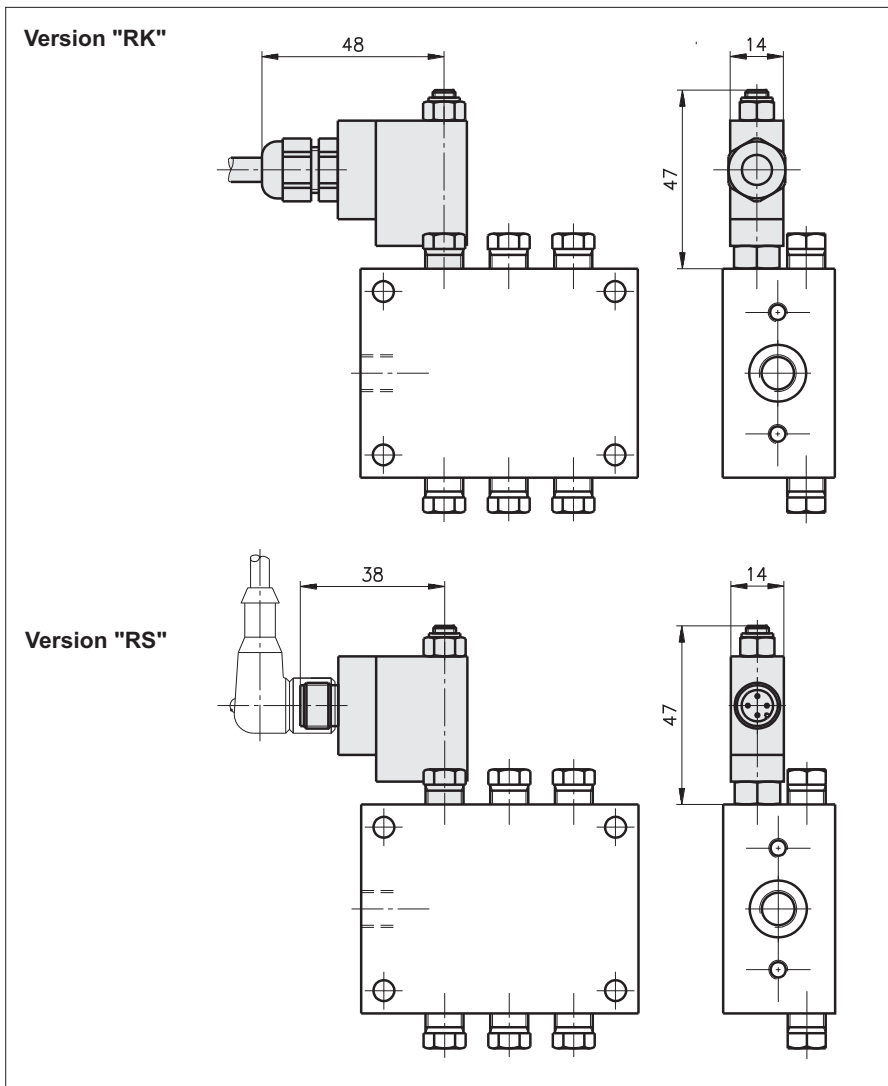

Electrical check with reed contact:

A magnet connected with the piston switches a reed contact once per cycle.

Switching voltage: 10 ... 36 VUC
 Switching current at max.: 25 mA
 Switching power at max.: 0,9 VA
 Ambient temperature: -5 ... +80 °C

Version "RK" with cable:

Material (receptacle): PA or 1.4305
 System of protection: IP65
 Cable
 Length: 10 m
 Cross section: 2x0,75 mm²
 Material: Oelflex

Connection diagram: BN — 100 R — BU

Version "RS" with unit plug, 4-pin (M12):

(for matching cable jack see auxiliaries)

Material (receptacle): PA or 1.4305

Connection diagram: 1 — 100 R — 4

Auxiliaries:

Cable jack for functional check "RS" and initiator "M3" (state purchase-no., please)

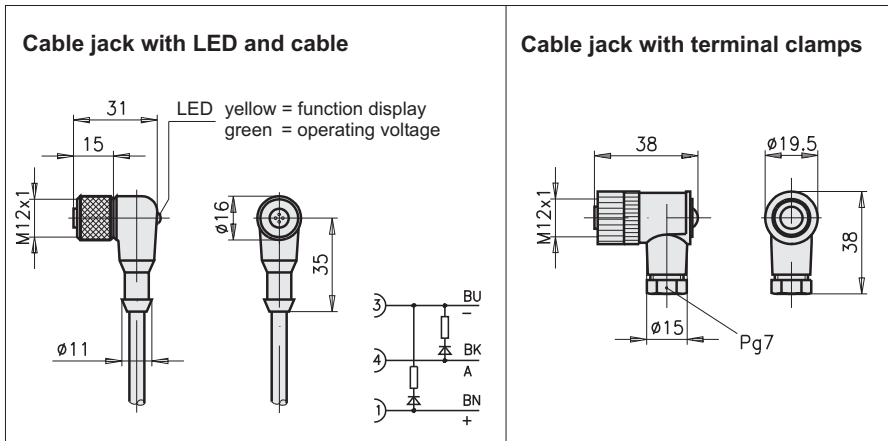

Cable jack with LED and cable:

Purchase-no.: 913.404-19
 Operating voltage: 10 ... 30 VDC
 Cable
 Cross section: 3x0,34 mm²
 Length: 5 m
 System of protection: IP68

Cable jack with terminal clamps: (without LED)

Purchase-no.: 913.404-24
 Connection type: Screws
 Connection cross section: at max. 0,75 mm²
 Cable diameter: 4 ... 6 mm
 System of protection: IP67



Purchase-designation: Progressive distributor VPB-

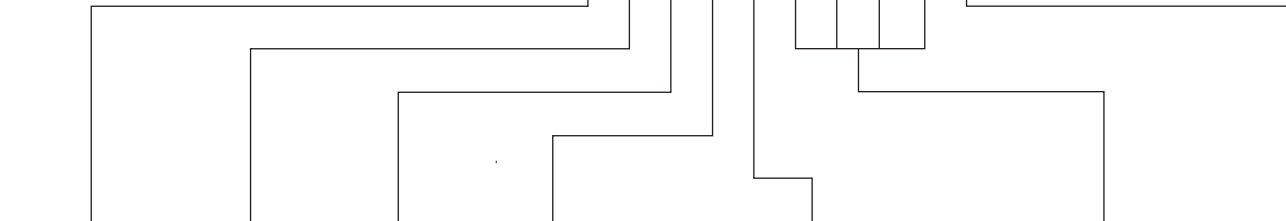

Material outer body	Number of outlets	Pipe screwing for outlet	Functional check		Prop. volume p. piston stroke and outlet [cm ³] distinctive no.	Gasket material		
			Visual check	electrical control				
Aluminium anodised	6 ... 20 increasing by 2 outlets each	without	without	without	0,09	NBR (Perbunan)		
Bronze seawater resistant		Ø4		Initiator with cable			Reed contact with cable	0,14
		Ø6		Initiator with plug			Reed contact with plug	0,20

- Subject to modifications -

Note:
When a functionality checking device is to be mounted, the proportioning volume must be 0,20 cm³ at the last point!
On the functionality checking device "M", the metering volume at the last point (opposite the initiator's side) decreases by 25 % for design-related reasons.

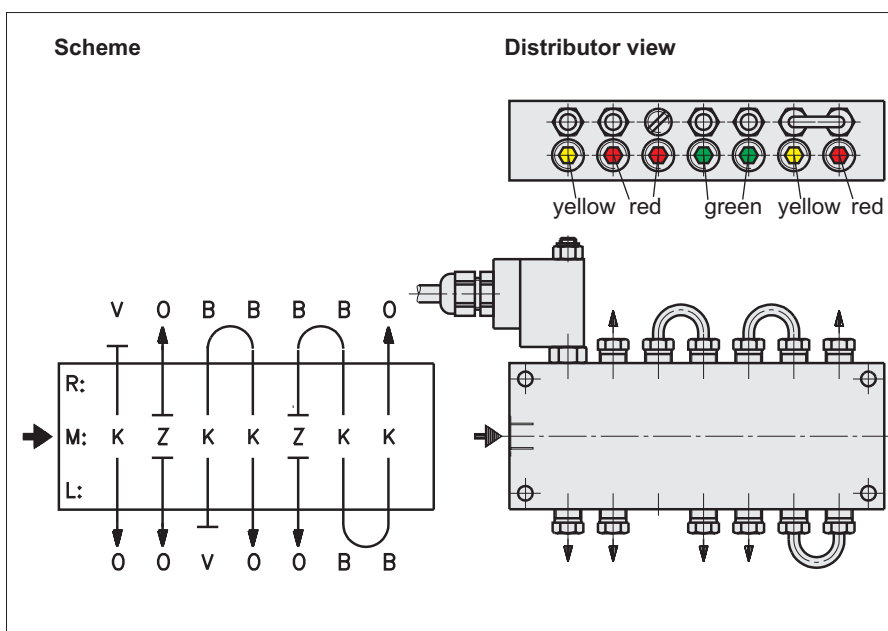

Purchase-example:
(for the distributor shown)

Progressive distributor VPB; outer body anodised; 14 outlets; for pipe outer diameter 6; without visual check; with reed contact (cable); Proportioning volume 14, 20, 20, 09, 09, 14, 20; gasket material viton.

Purchase-designation:
VPB-B / 14 / 6 / 0 / RK / 14 / 20 / 20 / 09 / 09 / 14 / 20 / V

R : V O B B B B O
M : K Z K K Z K K
L : O O V O O B B



**Combinaton of outlets,
doubling the proportioning volume at an outlet:**

Connect opposing outlets by removing the "Z" screw.
Close the not needed outlet with the lock screw.
Without "Z" screw removal, no outlet must be locked.

The "Z" screw can be loosened and removed by using a size 2 allen key.

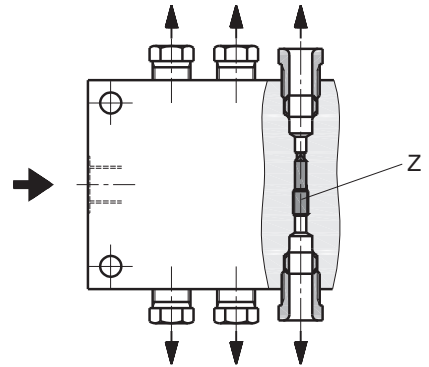

Auxiliaries:

Progressive distributor	Bridge	Lock screw	Pipe screwing Ø4	Pipe screwing Ø6	Check valve ALL (without pipe screwing)
VPB-B	205.507-65	205.502-45	205.533-65	205.532-65	501.085-65
VPB-H	205.507-61	205.502-41	205.533-61	205.532-61	-

- Subject to modifications -

Combination of outlets:

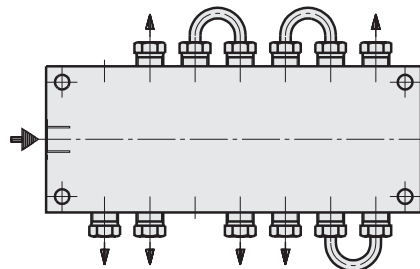

2 opposing outlets are combined into one outlet by removing the "Z" screw and closing the outlets.

5 outlets are combined by means of 2 bridges and removing two "Z" screws.

Distinctive letters:

- O = open outlet
- V = Locking screw
- B = double bridge
- K = opposing outlets connected.
- Z = opposing outlets separated.

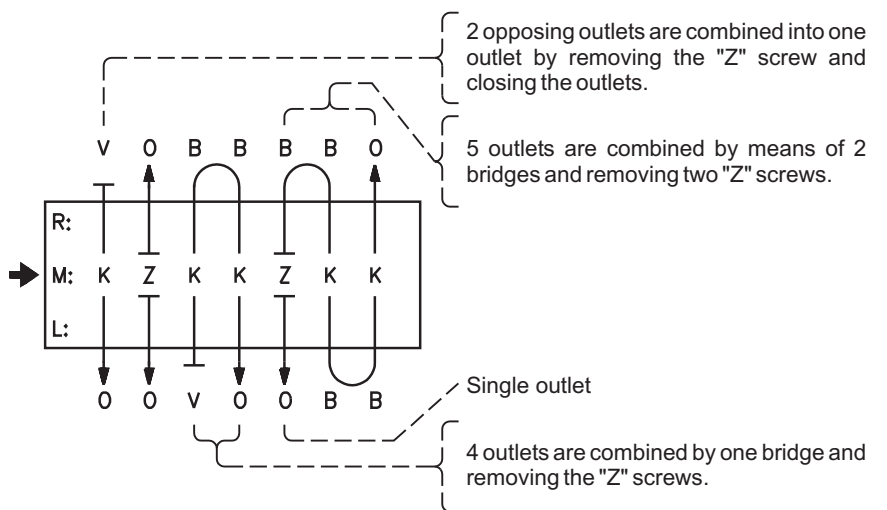

Single outlet

4 outlets are combined by one bridge and removing the "Z" screws.

Functional process fig. 1 ... 4:

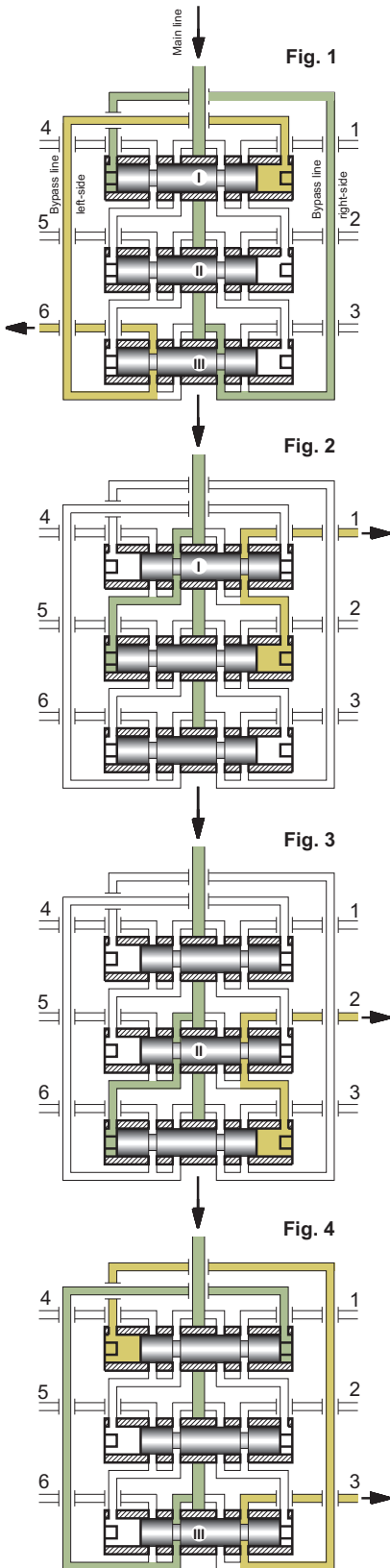

The lubricant flows from the main line through the right-side ring groove of piston III as well as the bypass line (right) and to the left side of piston I and moves it into its home position. The lubricant displaced by piston I is ejected via the left bypass line through outlet no. 6.

After shifting of piston I, lubricant flows to the left side of piston II and pushes it into its right-side home position. The displaced lubricant is ejected via outlet no. 1.

After shifting of piston II, lubricant flows to the left side of piston III and pushes it into its right-side home position. The displaced lubricant is ejected via outlet no. 2.

After shifting of piston III, lubricant flows to the right side of piston I and pushes it into its left-side home position. The displaced lubricant is ejected via outlet no. 3. The continuation of that process is evidenced in the scheme described.

Monitoring of progressive distributors:

As for instance due to soiling, the flow through a lubricant point line may be prevented. This will cause a piston to get blocked. By virtue of the forced control as depicted in figures 1 up to 4, the other pistons will be stopped as well. Due to this configuration, the proportioning at all outlets of the distributor can be monitored by means of a sensor at one piston only.

Mounting note:

The pistons are provided with an extremely small fitting clearance. Therefore, the pistons, after the dismantling of a distributor, must never be interchanged.

Formula for calculating the lubricant available per lubrication point:

A progressive distributor allocates the delivered lubricant to the individual lubrication points in forced order. Due to the functional process as described herein, a safe proportioning is ensured.

The lubricant q_i delivered to a lubrication point i can be calculated as follows

$$q_i = \frac{K_i}{2 * (K_1 + K_2 + K_3 \dots)} * Q$$

Q = lubricant delivered to the distributor,
 K_i = distinctive number of the outlet i

- Subject to modifications -